



**POZZETTI  
GELATO & BAR  
TECHNOLOGY**

## BRX UN'INDUSTRIA DAL CUORE ARTIGIANO

Ogni nostro prodotto è progettato e realizzato con cura e passione.

Ogni progetto richiede competenza, volontà e amore per il dettaglio, espressione tipica del miglior artigianato italiano

## BRX A COMPANY WITH AN ARTISAN HEART

All our products are designed and made with care and passion.

Each project requires expertise, will and love for details, the typical expression of the best Italian craftsmanship



# VISTA gelato

## GELATO REVOLUTION



IN ATTESA DI BREVETTO



### VISTA

Vetrina canalizzata 10+6 gusti  
Display case composition 10+6 flavors

**VISTA** RAPPRESENTA LA RIVOLUZIONE DEL BANCO POZZETTI E ALLO STESSO TEMPO L'EVOLUZIONE DELLA TRADIZIONALE VETRINA GELATO. **VISTA** REPRESENTS THE REVOLUTION OF THE POZZETTI COUNTER AND AT THE SAME TIME THE EVOLUTION OF THE TRADITIONAL GELATO DISPLAY CASE.



IN ATTESA DI BREVETTO

# VISTA gelato

EVOLUZIONE DEL BANCO POZZETTI A GLICOLE  
*EVOLUTION OF GLYCOL POZZETTI COUNTER*



## CARAPINA

Capacità 7 Lt - 5 Kg

Capacity 7 Lt - 5 Kg



Sistema  
antirotazione  
Anti-spin  
system

150

260

### Elevata visibilità

ed innovativa  
esposizione del gelato.  
Il gelato è esposto  
in carapine di dimensioni  
maggiori con  
un diametro di 260 mm  
che ne migliorano  
la visibilità e  
ne facilitano l'utilizzo

### High visibility

and innovative way  
to showcase the gelato.  
The gelato is contained  
into large carapinas of  
diameter 260 mm which  
improves the visibility  
and the ease of use



IN ATTESA DI BREVETTO

# VISTA gelato

UNA VETRINA DUE TECNOLOGIE  
ONE DISPLAY CASE TWO TECHNOLOGIES

## REFRIGERAZIONE VENTILATA VENTILATED COOLING

La perfetta sinergia tra la refrigerazione a glicole e la refrigerazione ventilata consentono l'utilizzo del banco senza coperchi e di conseguenza il gelato è visibile

The perfect synergy between the glycol cooling and the ventilated cooling enables to use the counter without lids and consequently the gelato is visible

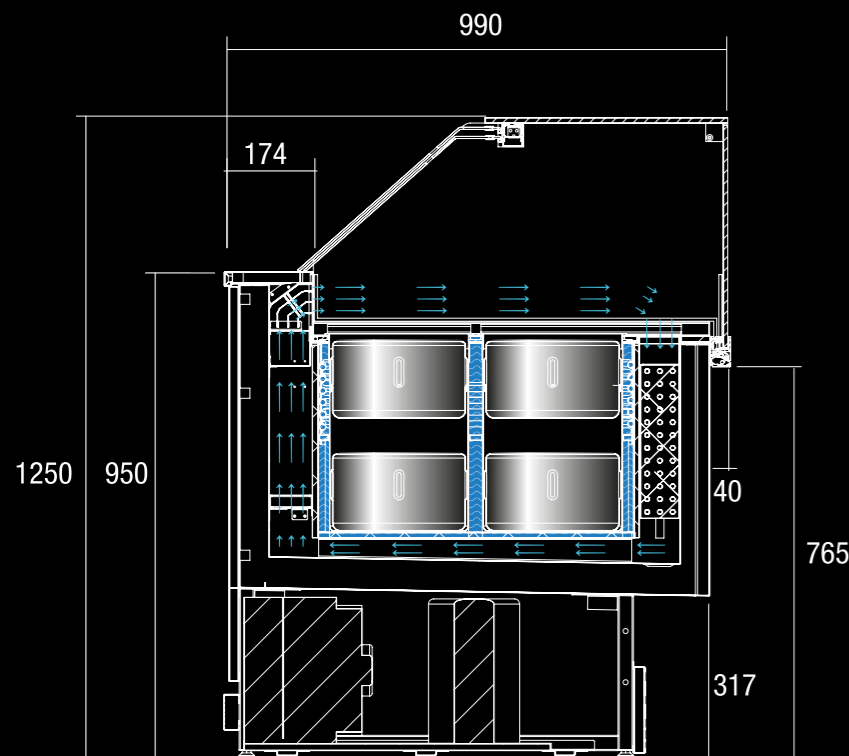

## REFRIGERAZIONE A GLICOLE GLYCOL COOLING

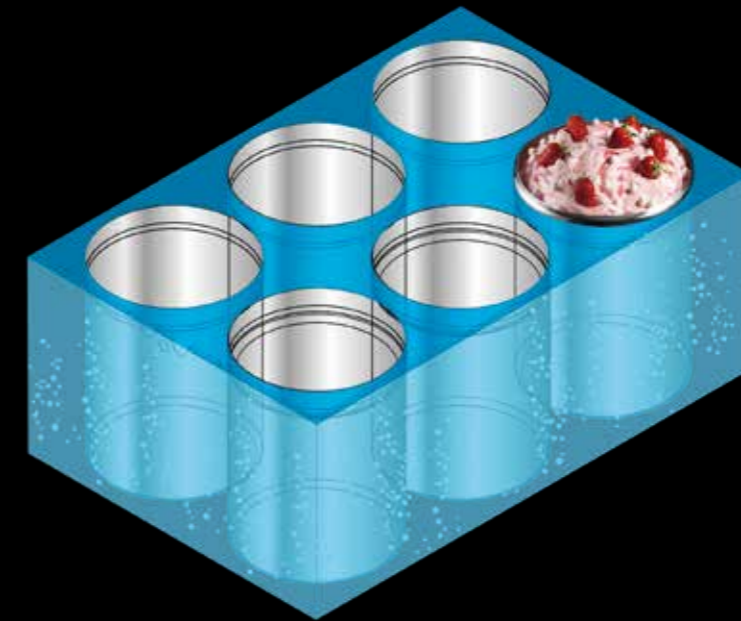

### VISTA è dotata di due compressori tra loro indipendenti

che consentono di continuare il servizio anche in caso di rottura. In caso di interruzione dell'energia elettrica il glicole ha la proprietà di conservare il gelato per ore.

### More autonomous conservation of gelato

in case of compressor failure or power cut: VISTA is equipped with two independent compressors and in addition the glycol's cold properties will maintain the gelato at low temperature for many hours





IN ATTESA DI BREVETTO

# VISTA gelato

UNA VETRINA DUE LIVELLI  
*ONE DISPLAY CASE TWO LAYERS*



CARAPINA  
DI SERVIZIO  
*CARAPINA  
FOR SERVICE  
UPPER LAYER*

SECONDA  
CARAPINA  
DI RISERVA  
*STORAGE  
SECOND  
CARAPINA*



IN ATTESA DI BREVETTO

# VISTA gelato

UNA VETRINA DUE CONFIGURAZIONI  
ONE DISPLAY CASE TWO CONFIGURATIONS



**VISTA** è dotata di un doppio livello di carapine: la carapina di servizio e la carapina di riserva così da avere un'ampia capacità di stoccaggio

**VISTA** is equipped with a double layer of carapinas: upper layer for service and storage



**VISTA** non è solo un innovativo banco espositivo ma anche un banco di conservazione. Alla chiusura serale le carapine vengono posizionate su un livello più basso (al contrario delle tradizionali vetrine ventilate dove le vaschette vengono rimosse) e si mettono i coperchi. Il glicole conserva il gelato per il giorno dopo garantendo un notevole risparmio economico, di tempo e spazio.

**VISTA** is not only an innovative display counter but it is also a night time storage. Each evening the carapinas are lowered of a few cms (on the contrary in a traditional scooping display case the containers must be removed) and the lids are placed. The glycol preserves the gelato over the night for the day after saving money, time and space.

## CONFIGURAZIONE DIURNA DAY-TIME SET UP

No coperchio ed eccezionale visibilità del gelato

No lid and exceptional visibility

**RISERVA**  
Seconda carapina

**STORAGE**  
Second carapina

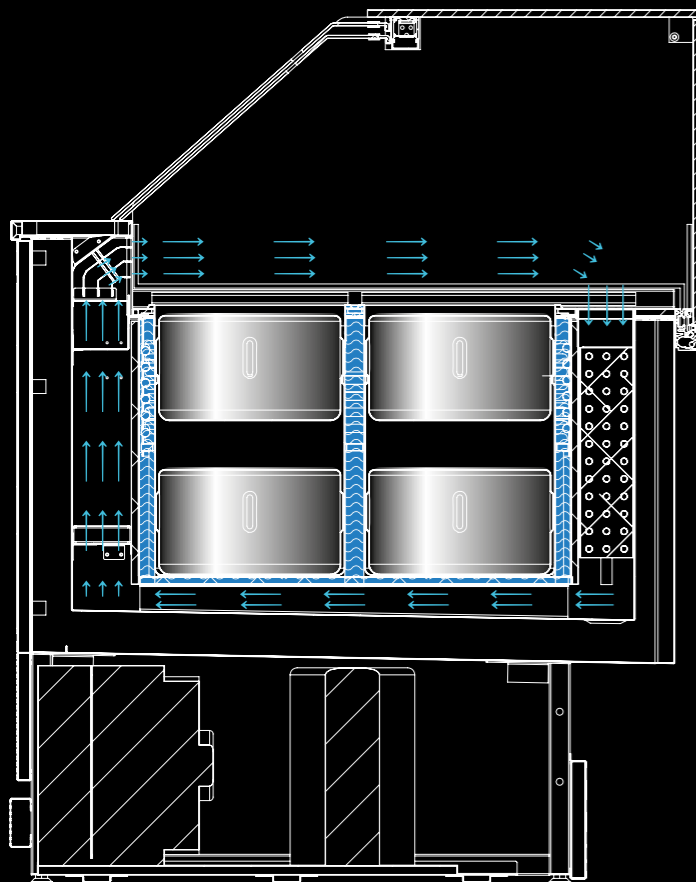

## CONFIGURAZIONE NOTTURNA NIGHT-TIME SET UP

Carapina posizionata ad un livello più basso e coperchio per proteggere

Carapina placed at a lower level + lid

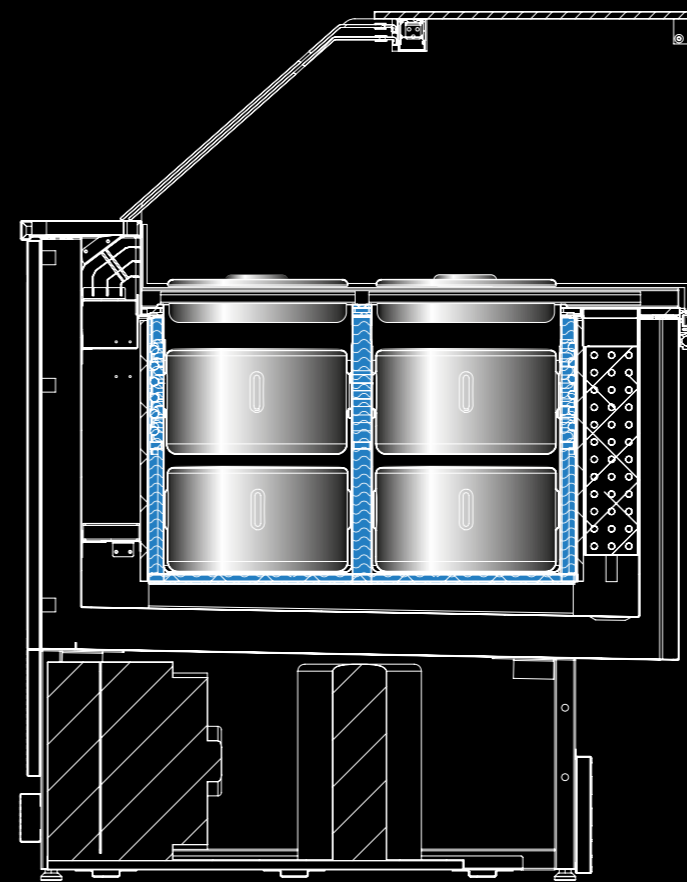



IN ATTESA DI BREVETTO

# VISTA 3 FILE

EVOLUZIONE DEL BANCO POZZETTI A GLICOLE  
*EVOLUTION OF GLYCOL POZZETTI COUNTER*



## CARAPINA

Capacità 7 Lt - 5 Kg

Capacity 7 Lt - 5 Kg



Sistema  
antirotazione  
Anti-spin  
system

250

200

**Elevata visibilità**  
ed innovativa  
esposizione del gelato.  
Ancora più gusti  
grazie all'esposizione  
su 3 file

**High visibility**  
and innovative way  
to showcase the gelato.  
More flavors thanks  
to the 3 row configuration





IN ATTESA DI BREVETTO

# VISTA gelato

UNA VETRINA DUE FUNZIONI  
ONE DISPLAY CASE TWO FUNCTIONS

LA GELATERIA  
DIVENTA ANCHE PASTICCERIA  
per un uso 365 giorni all'anno

THE GELATO COUNTER TURNS  
INTO A PASTRY COUNTER  
for an use 365 days a year



Il banco **VISTA** gelato può essere **convertito** in un **banco pasticceria** nell'arco anche della stessa giornata, con il solo **utilizzo della tecnologia glicole** per una perfetta conservazione del prodotto favorendo di conseguenza anche un risparmio energetico

**VISTA** gelato can be converted into a **pastry counter** even during the same day, only by using glycol cooling for a perfect preservation of the product as well as energy saving



IN ATTESA DI BREVETTO

# VISTA gelato

LA GAMMA: DA 6 A 14 GUSTI  
THE RANGE: FROM 6 TO 14 FLAVORS

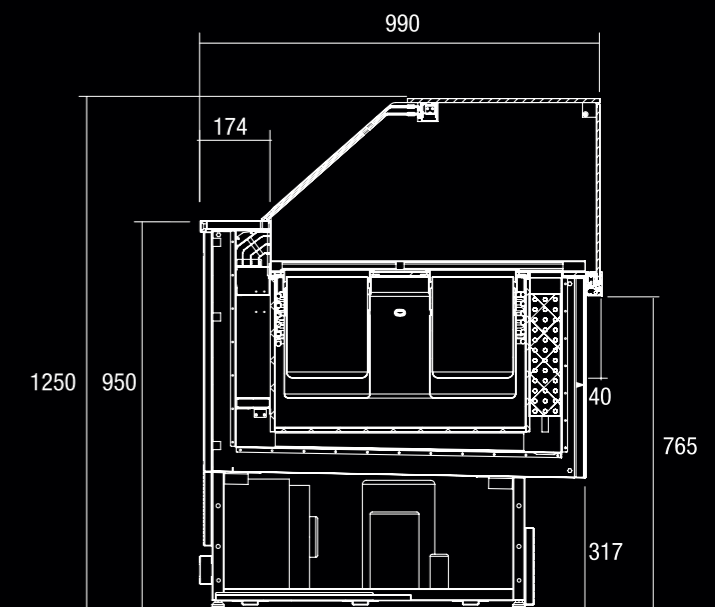
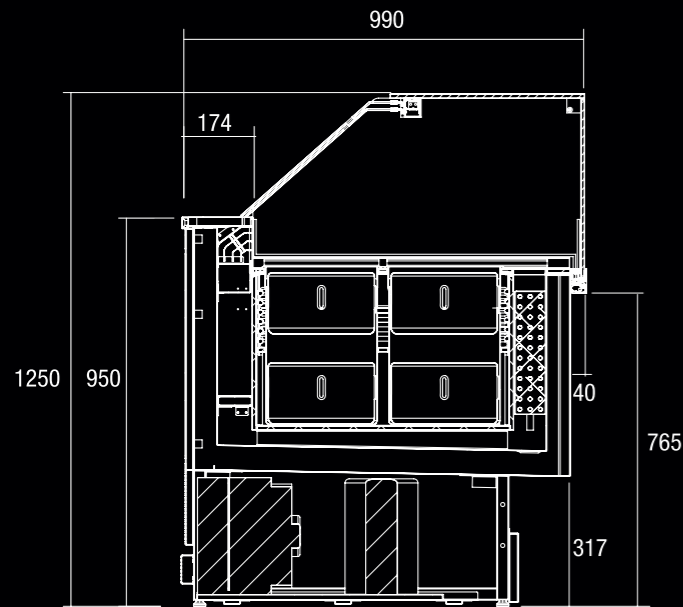

**CARAPINA**  
Capacità 7 Lt - 5 Kg  
Capacity 7 Lt - 5 Kg



150

260



**CARAPINA**  
Capacità 7 Lt - 5 Kg  
Capacity 7 Lt - 5 Kg



250

200

**VISTA** Disponibile nei moduli L. 1050 mm (6+6 riserva) e L. 1650 mm (10+10 riserva). Possono essere tra loro canalizzati  
**VISTA** Available in the modules L. 1050 mm (6+6 storage) and L. 1650 mm (10+10 storage). They can be multiplexed

**VISTA** Disponibile nei moduli L. 1050 mm (8) e L. 1650 mm (14). Possono essere tra loro canalizzati  
**VISTA** Available in the modules L. 1050 mm (8) and L. 1650 mm (14). They can be multiplexed

# VISTA pastry

UNA VETRINA PASTICCERIA FUNZIONALE E DI DESIGN  
*A FUNCTIONAL AND DESIGN PASTRY DISPLAY CASE*



## VISTA

Composizione vetrine canalizzate L. 1300 + L. 1700  
Display cases composition L. 1300 + L. 1700

# VISTA pastry

UNA VETRINA PASTICCERIA FUNZIONALE E DI DESIGN  
*A FUNCTIONAL AND DESIGN PASTRY DISPLAY CASE*

VISTA è anche **vetrina pasticceria** e si contraddistingue per l'alta visibilità del prodotto esposto. Disponibile nei moduli freddo ventilato e caldo secco

VISTA is also **pastry display case** and it distinguishes itself for the high visibility of the product displayed. Available in the configurations cold ventilated and dry-heat

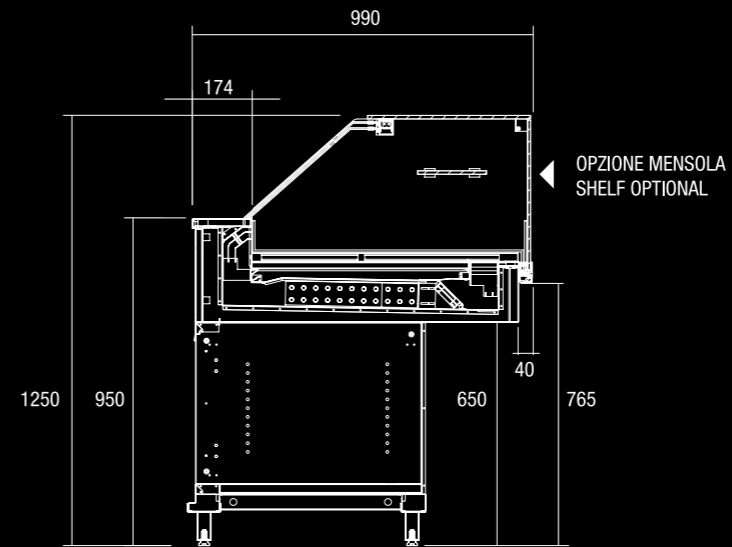

VISTA è disponibile con cella refrigerata di riserva.

*VISTA is available with refrigerated underneath storage*



**VISTA** Disponibile nei moduli L. 1300, 1700 e 2100 mm. Possono essere canalizzati tra loro e con qualsiasi modulo VISTA gelateria.  
**VISTA** Available in the modules L. 1300, 1700 e 2100 mm. They can be multiplexed and joined to any VISTA gelato module

# VISTA gelato+pastry

PERFETTA COMBINAZIONE  
*PERFECT COMBINATION*

PERFETTA CANALIZZAZIONE TRA TUTTI I MODULI **VISTA**  
ALL THE **VISTA** MODULES CAN BE COMBINED TOGETHER



# BRX

BANCHI POZZETTI GELATO  
*POZZETTI COUNTERS FOR GELATO*



LA PIÙ AMPIA GAMMA SUL MERCATO  
*THE WIDEST RANGE IN THE MARKET*

I BANCHI POZZETTI A GLICOLE RAPPRESENTANO LA MIGLIORE SOLUZIONE PER MANTENERE IL GELATO ASSICURANDO UN RISPARMIO ENERGETICO E DI LAVORO  
*THE GLYCOL POZZETTI COUNTERS ARE THE IDEAL SOLUTION TO MAINTAIN THE GELATO AT BEST BY SAVING ENERGY & LABOUR*

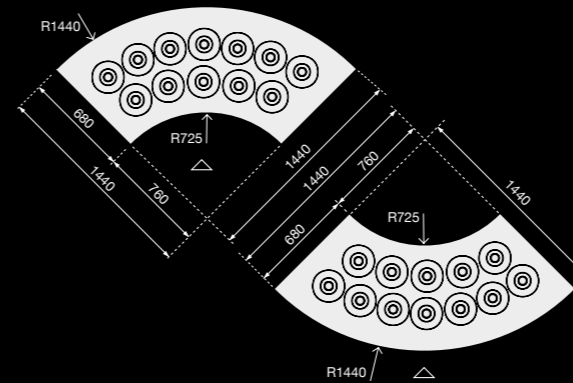
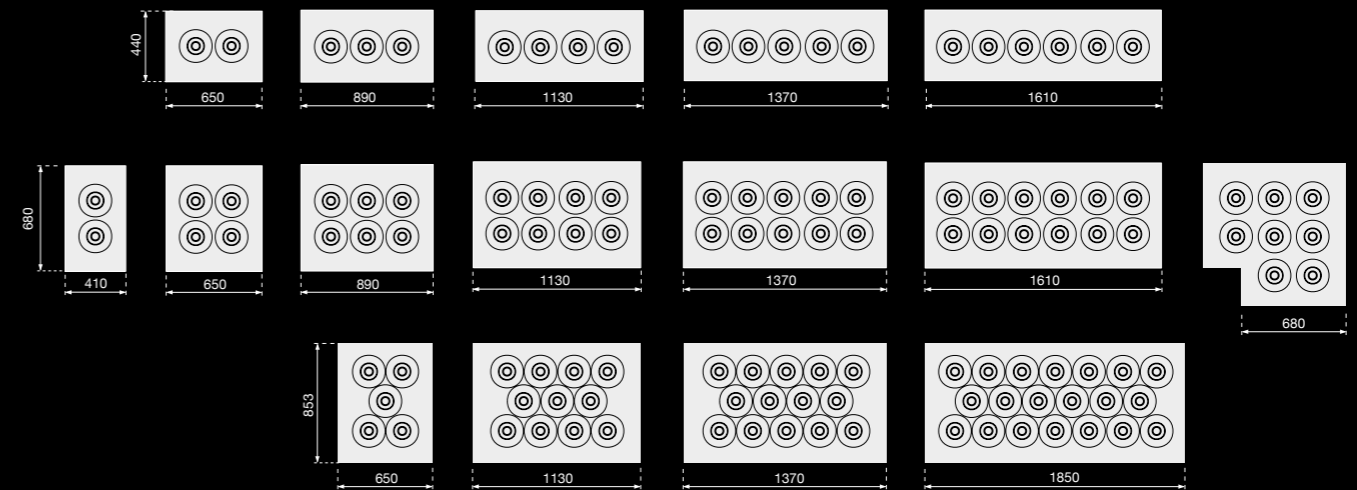

## CONFIGURATIONS

BRX propone banchi pozzetti gelati da 2 a 20 gusti, disponibili sia in moduli lineari che ad angolo, con e senza riserva, ad una, due e tre file di carapine. Rappresentano la migliore scelta per la gelateria artigianale e di qualità.

BRX offers pozzetti counters for gelato from 2 up to 20 flavors, available both in linear and corner configurations, with and without storage; with one, two and three rows of carapinas. They represent the best choice for the artisanal and quality ice cream parlours.

BANCHI POZZETTI A GLICOLE PER GELATO  
*GLYCOL POZZETTI COUNTERS FOR GELATO*SPECIFICALLY  
FOR YOU

La qualità, la tecnologia e l'ampia gamma dei banchi pozzetti gelato BRX permettono di **creare ambienti gelateria unici** rispondendo alle più diverse esigenze espositive e di layout del cliente.

The quality, the technology and the wide range of BRX pozzetti counters enable **to create unique gelato** environments meeting any customer's need related to display and layout





# GLYCOL POZZETTI COUNTERS

VANTAGGI TECNOLOGICI DI BRX  
BRX TECHNOLOGICAL ADVANTAGES

## DELTA 0

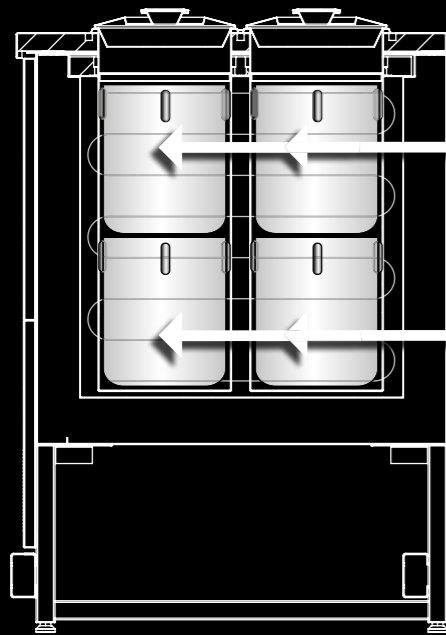

### DELTA 0

stessa temperatura tra la parte superiore e quella inferiore del banco per un'immediata spatolabilità del gelato della carapina di riserva

### DELTA 0

Same temperature throughout the upper and lower carapina enabling to scoop instantly the gelato kept into the carapina of the storage

1

## TECNOLOGIA

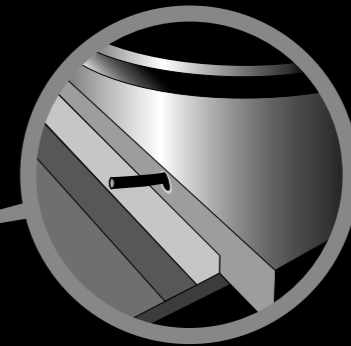
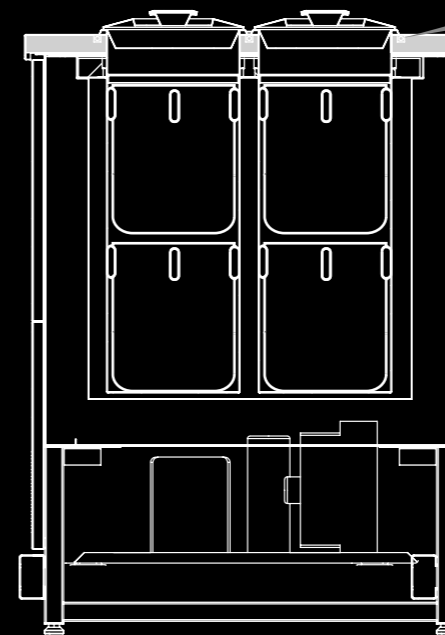

### TOP CON SISTEMA ANTICONDENSA

anche per progetti su misura e top personalizzati

### CONDENSATION-PROOF HEATED TOP

Even for counter compositions and personalized top

3

## ENERGY SAVING

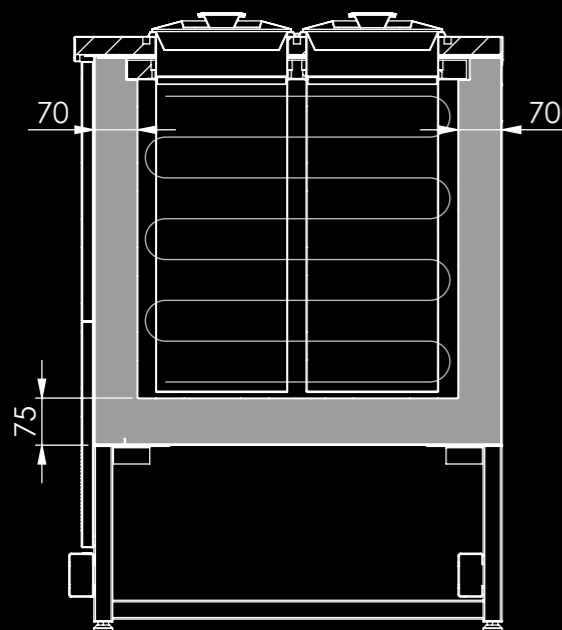

### RISPARMIO ENERGETICO

Maggiore isolamento del banco grazie al più elevato spessore di coibentazione della vasca, 70 e 75 mm.

Maggiore efficienza energetica grazie al contatto diretto della serpentina in rame con il liquido refrigerante.

### ENERGY SAVING

Energy saving: bigger foam thickness of the counter 70 and 75 mm. and consequently better insulation

Great cooling efficiency: copper coil in direct contact with the glycol.

2

## SPACE SAVING

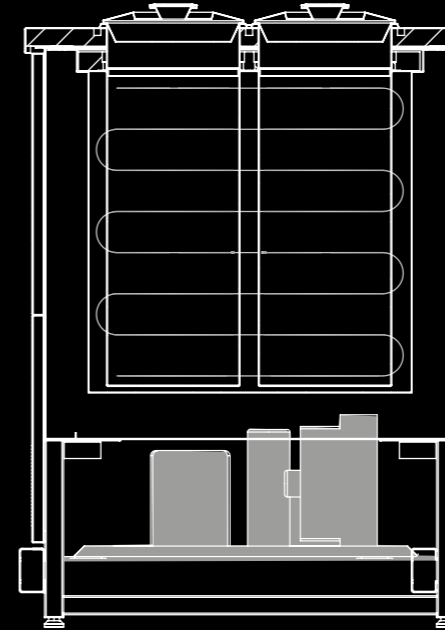

### PIÙ GUSTO IN MENO SPAZIO

Sia l'unità condensatrice ad aria che ad acqua possono essere posizionate sotto la riserva

### MORE FLAVORS IN LESS SPACE

Both air-cooled and water cooled condensing units can be placed under the storage

BRX OTTIMIZZA LO SPAZIO DEL TUO LOCALE  
BRX OPTIMIZES THE SPACE OF YOUR SHOP



4

# VINTAGE mobile pozzetti

IL GELATO DI QUALITÀ SU RUOTE  
MOBILE SOLUTION FOR QUALITY GELATO

vintage  
**POZZETTO**  
High Quality

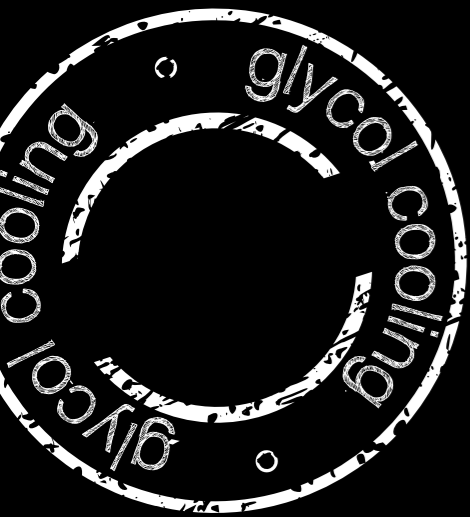

CON RISERVA  
WITH STORAGE

SENZA RISERVA  
WITHOUT STORAGE

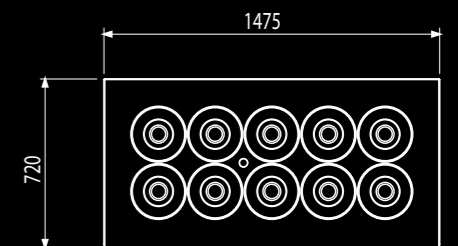
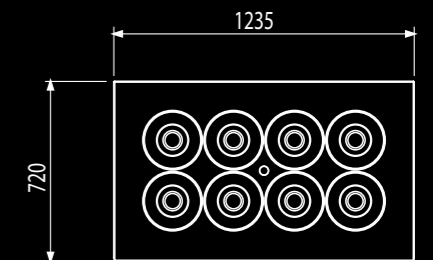
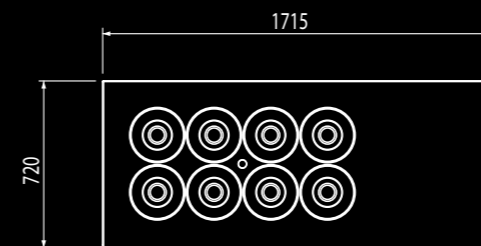
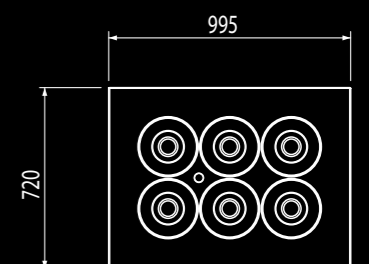
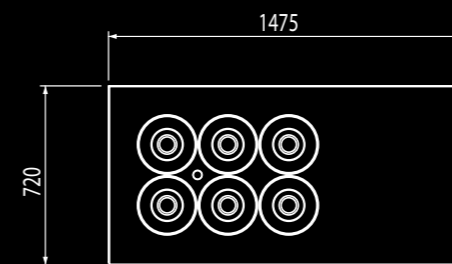
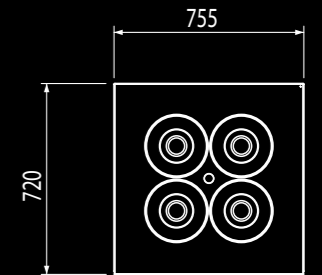
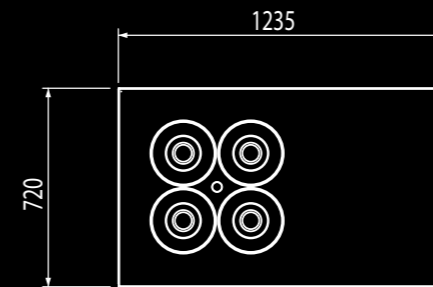

# VIVI mobile pozzetti

IL GELATO DI QUALITÀ SU RUOTE  
MOBILE SOLUTION FOR QUALITY GELATO



SENZA RISERVA  
WITHOUT STORAGE

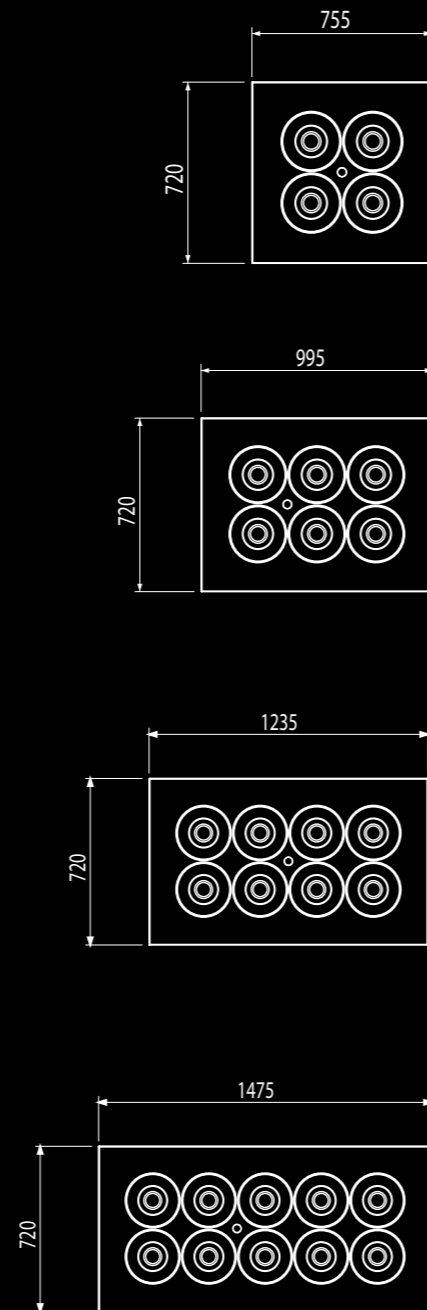

# JOY mobile pozzetti

NUOVA SOLUZIONE SMART DI BRX  
NEW BRX SMART SOLUTION



JOY



CON RISERVA  
WITH STORAGE

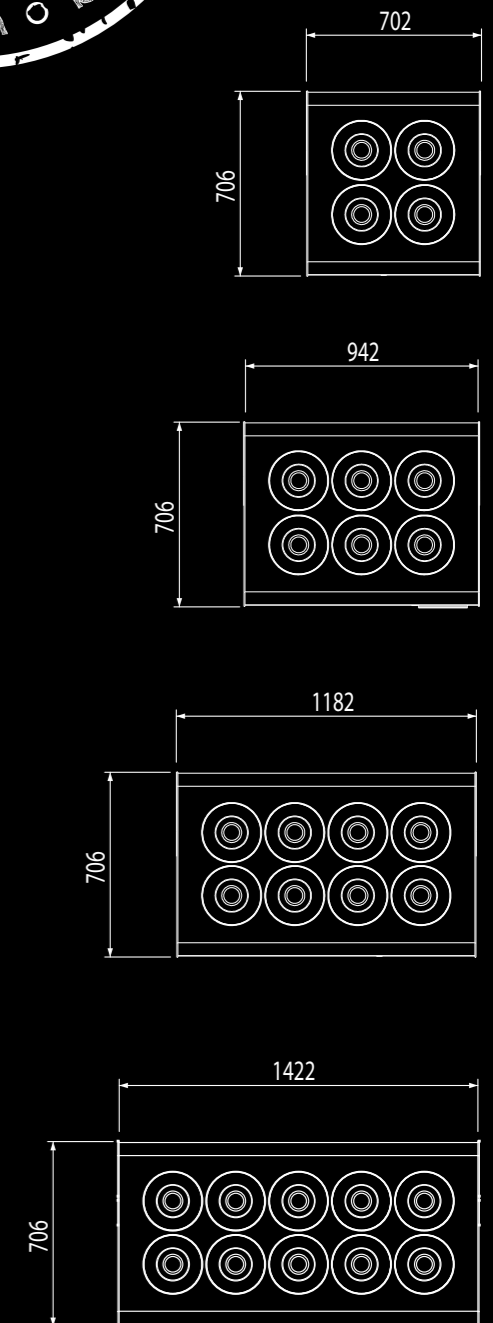

# CELLE 6.5 REFRIGERATED UNDER COUNTERS 6.5

È TEMPO DI PASSARE AD UN NUOVO STANDARD  
*IT IS TIME TO MOVE TO A NEW STRANDARD*



# CELLE 6.5 REFRIGERATED UNDER COUNTERS 6.5

È TEMPO DI PASSARE AD UN NUOVO STANDARD  
*IT IS TIME TO MOVE TO A NEW STRANDARD*

La gamma si compone di moduli di diverse lunghezze, disponibili in 2 profondità (670 e 770 mm) e 2 altezze (770 e 880 mm). Tecnologia di refrigerazione a serpentina affogata. Disponibili sia nella versione TN (0+6°C) e BT (-18°C-20°C)

The range comprises of modules of different lengths, available in 2 depths (670 and 770 mm) and 2 heights (770 and 880 mm). Refrigerated technology concealed cooling coil. Available both as the refrigerator (0+6°C) and freezer (-18°C-20°C)

**H770**  
2 cassetti uguali  
2 identical drawers

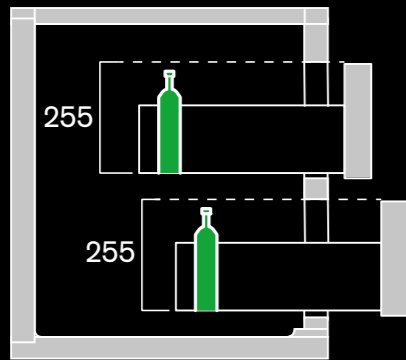

**H880**  
2 cassetti uguali  
2 identical drawers

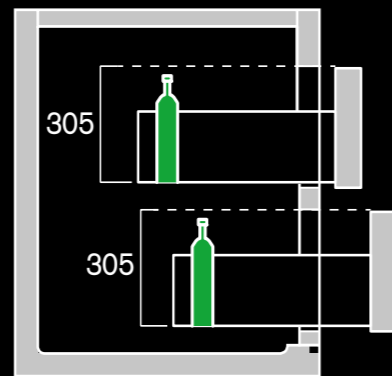

Nuova cella  
e banco bar  
con spessore  
di coibentazione  
65 mm

New  
undercounter  
and bar counter  
with insulation  
thickness  
65 mm

# CELLE 6.5 REFRIGERATED UNDER COUNTERS 6.5

TECNOLOGIA BAR DA PERSONALIZZARE  
*BAR TECHNOLOGY TO PERSONALIZE*

Le ante sono predisposte  
per applicare finiture fino  
a 6 mm di spessore.

The doors are designed  
to apply finish materials  
until 6 mm thickness

FINITURE DA PERSONALIZZARE  
PERSONALIZED FINISHES



# CELLE 6.5 REFRIGERATED UNDER COUNTERS 6.5

LA GAMMA  
THE RANGE

PORTE IN VETRO  
GLASS DOORS

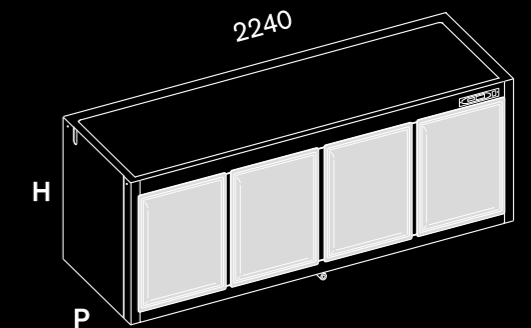
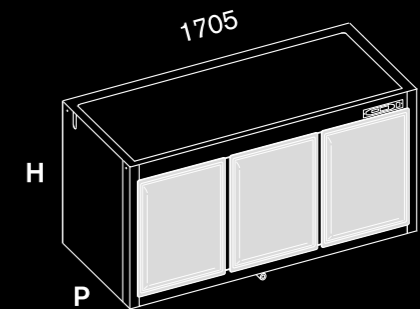
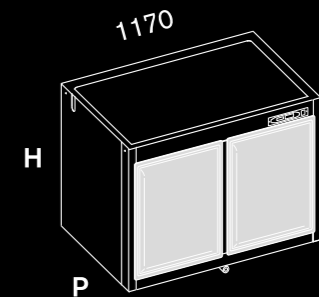
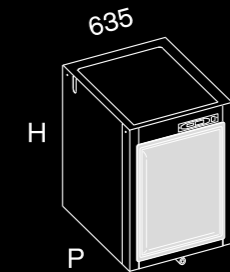
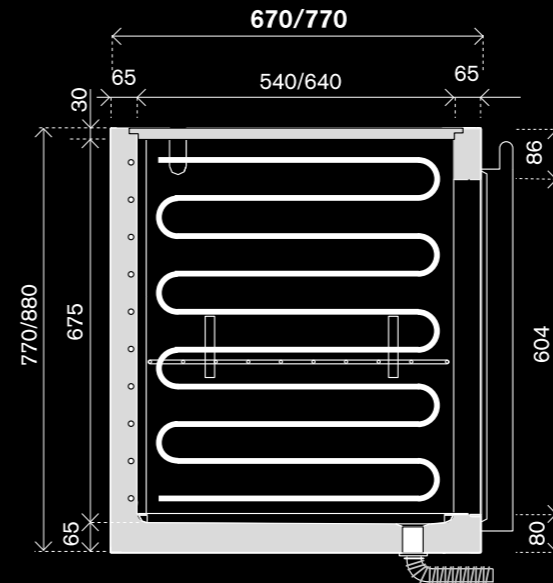

# DROP-IN

TECNOLOGIA E MODULARITÀ PER IMMAGINARE  
E REALIZZARE QUALSIASI TIPOLOGIA DI LOCALE  
*TECHNOLOGY AND MODULARITY TO IMAGINE AND  
REALIZE ANY KIND OF PLACE*





# DROP-IN

## LE FUNZIONI THE FUNCTIONS



- DISPONIBILE  
AVAILABLE
- NON DISPONIBILE  
NOT AVAILABLE

DUAL

NEA

P60

P80

FRUTTINI/ TOPPINGS

BASSA TEMPERATURA  
FREEZER

●

—

●

—

—

FREDDO STATICO  
STATIC COLD

●

—

●

●

●

FREDDO STATICO A CONTATTO  
STATIC COLD CONTACT

—

—

●

●

—

FREDDO VENTILATO  
VENTILATED COLD

●

●

●

●

—

FREDDO VENTILATO PRALINERIA  
VENTILATED COLD FOR PRALINE

●

●

—

—

—

DOPPIO IMPIANTO FREDDO VENTILATO/CALDO SECCO  
DUAL MODE FUNCTION (VENTILATED COLD / DRY-HEAT)

●

●

●

●

—

CALDO SECCO  
DRY-HEAT

—

●

●

●

●

BAGNO MARIA  
BAIN-MARIE

—

—

●

—

—

COCKTAIL  
COCKTAIL

—

—

●

—

—

NEUTRA  
NEUTRAL

—

—

—

—

●

TUTTE LE VASCHE SONO DISPONIBILI ANCHE NELLA OPZIONE BANCO  
ALL THE DROP-IN ARE AVAILABLE ALSO IN THE OPTION FULL COUNTER

# DROP-IN NEA

PASTICCERIA E PRALINERIA  
*PASTRY AND PRALINE*

La perfetta canalizzazione tra più moduli crea un'unica superficie espositiva senza interruzioni.

Perfectly canalized modules create a single continuous display surface.

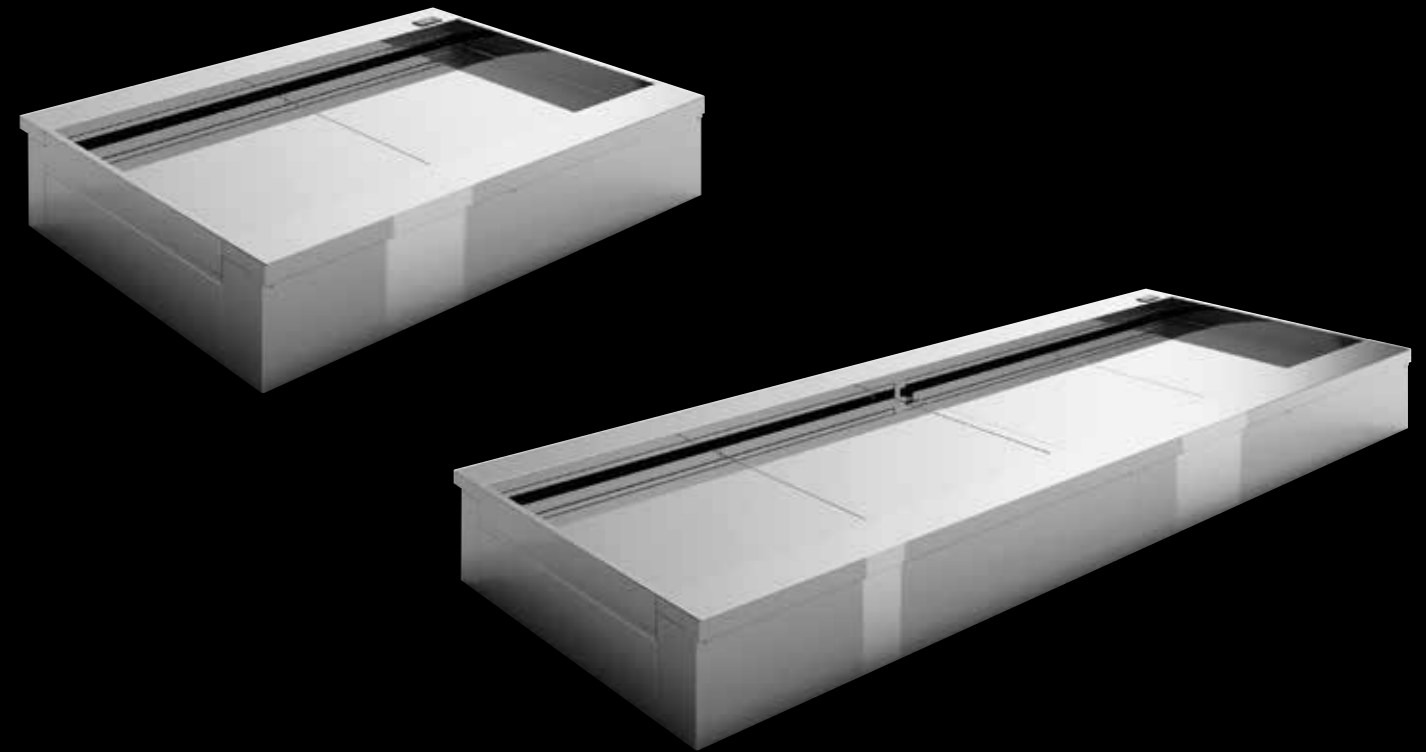

Le nostre vasche sono studiate per adattarsi ad ogni tipo di materiale, perfette per qualsiasi tipo di rivestimento, per ottenere sempre il risultato estetico desiderato.

Our drop-in are designed to fit any type of material, perfect for any type of finishing to consistently achieve the desired aesthetic result.

# DROP-IN

BASSA TEMPERATURA: VASCHE GELATO, PORTASTECCHI E TORTE GELATO  
 FREEZER FOR: GELATO TRAYS STICKS, HOLDERS AND CAKES

L=1088 n° 2

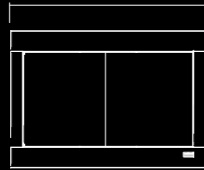

L=1580 n° 3

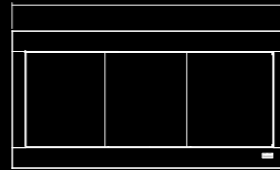

Piani espositivi in acciaio inox  
 Stainless Steel Trays

L=1088 n° 6+6 x 1/4 GN

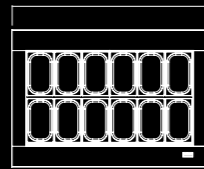

L=1580 n° 9+9 x 1/4 GN

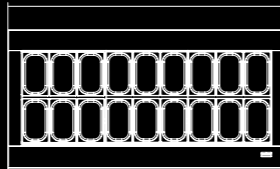

**Optional:**  
 Vaschette GN per gelato  
 GN pots for gelato

1/4 GN 265x162x h 100 mm  
 2/4 GN 530x162x h 100 mm

L=1088 n° 2

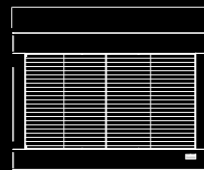

L=1580 n° 3

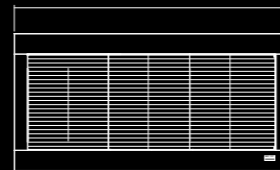

**Optional:**  
 Vassoi porta stecchi in acciaio inox  
 Stick holder trays in stainless steel

L=1088

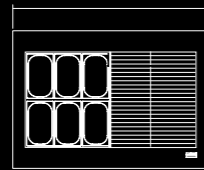

L=1580

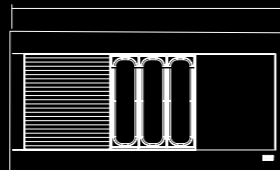

**MASSIMA FLESSIBILITÀ  
 MAXIMUM FLEXIBILITY**  
**Optional:**  
 Combinazione di vaschette GN, vassoio  
 porta stecchi e vassoio porta torte gelato  
 Combination of GN pots, stick  
 holder trays and trays for cakes

LE VASCHE BASSA TEMPERATURA DUAL E P60, INSIEME ALLA GAMMA DI VASCHE PER FRUTTINI, RAPPRESENTANO LA SOLUZIONE IDEALE PER QUALSIASI TIPO DI PROGETTO RIGUARDANTE IL GELATO

THE FREEZER WELLS DUAL & P60, ALONG WITH THE FRUTTINI RANGE, REPRESENT THE IDEAL SOLUTION FOR PROJECTS RELATED TO GELATO



NEUTRA  
 NEUTRAL

REFRIGERATA  
 REFRIGERATED

CALDA  
 HOT



#### Credits

This catalogue  
has been made by BRX  
in collaboration with

Project coordinator  
**feligioni.it**

Photo  
**Livio Fantozzi**  
Styling  
**Marida Gajtani**  
Graphic layout  
**Daniele Feligioni**

#### BRX srl

Via Luciano Lama, 38/1  
61025 Montelabbate (PU) Italy  
T +39 0721 499611  
F +39 0721 909376  
info@brxitalia.com  
www.brxitalia.com

IL CATALOGO È DI PROPRIETÀ BRX SRL. TUTTI I DIRITTI SONO RISERVATI.  
È VIETATA OGNI FORMA DI RIPRODUZIONE ANCHE PARZIALE.

*THIS CATALOGUE IS OF EXCLUSIVE PROPRIETÀ OF BRX SRL. ALL RIGHTS  
ARE RESERVED. ANY FORM OF TOTAL OR PARTIAL REPRODUCTION OF  
CATALOGUE IS STRICTLY FORBIDDEN.*

BRX SRL SI RISERVA DI APPORTARE MODIFICHE AI DATI E I DETTAGLI  
DEI PRODOTTI PRESENTI SU QUESTO CATALOGO ANCHE SENZA PREAVVISO.  
*BRX SRL MAY AT ANY TIME MODIFY THE SPECIFICATIONS  
AND DETAILS OF THE PRODUCTS PRESENT IN THE CATALOGUE.*



**BRX srl** Via Luciano Lama, 38/1 - 61025 Montelabbate (PU) - Italy  
Tel. +39 0721 499611 - Fax +39 0721 909376 - [info@brxitalia.com](mailto:info@brxitalia.com)  
[www.brxitalia.com](http://www.brxitalia.com)