

SCHEDA TECNICA | DATA SHEET



Salumi e formaggi

- classe di temperatura M2
- test a 25°C e 60% U.R.

Cured meat & cheese:

- temperature class M2
- test at 25°C and 60% R.H.



CARATTERISTICHE TECNICHE

STRUTTURA

- 4 ripiani inclinabili profondi 340 mm.
- Vasca, schienale e ripiani in lamiera zincata verniciata a polveri RAL 7021 nero opaco.
- Pannello frontale superiore e inferiore in lamiera verniciata a polveri RAL 7021 nero opaco.
- Basamento in lamiera verniciata a polveri RAL 7021 nero opaco, o verniciata a campione.
- Fianchi terminali disponibili in vetrocamera spessore 30 mm con serigrafie nere; oppure fianchi ciechi in lamiera nera RAL 7021 spessore 40 mm, con o senza specchiatura interna.
- Illuminazione LED 4000°K a effetto luce naturale posta nella parte superiore.
- Frontalino in vetro H125 mm.

REFRIGERAZIONE

- Refrigerazione ventilata.
- Unità condensatrice a bordo con gas R290; unità condensatrice remota con gas R452A.
- Sbrinamento ventilato con arresto del compressore.
- Vaschetta evapora condensa con resistenza elettrica per espositori con motore a bordo (UC) con gas R290.
- Scarico a terra per espositori senza motore a bordo (NUC).
- Ventole a basso consumo per versioni UC con gas R290.
- Pannello comandi full touch, antipolvere e resistente all'acqua.

OPTIONAL

- Chiusura anteriore con tendina manuale notturna.
- Canalizzazione tra espositori con lo stesso servizio senza interruzioni.
- Ripiano espositivo aggiuntivo.
- Illuminazione LED 4000°K sui ripiani.
- Gancera appendi salumi al posto del ripiano superiore.
- Portaprezzi in plastica trasparente e frontalino ferma prodotto in metacrilato.
- Ruote per vetrine con motore a bordo (UC), con aumento altezza di 80 mm.

GOODY BISTROT è disponibile nei seguenti moduli lineari, senza fianchi:
L625, L937, L1250 e L1875 mm con altezza H2060 mm.

Fianchi terminali disponibili in 2 versioni:

- 1 fianco in vetro camera, spessore 30 mm
- 1 fianco cieco, spessore 40 mm

TECHNICAL FEATURES

STRUCTURE

- 4 tilting shelves - 340 mm deep.
- Back and shelves in galvanized metal sheet painted in epoxy powder black RAL 7021.
- Upper and lower front panels in metal sheet painted in matt black RAL 7021.
- Base in metal sheet painted in matt black RAL 7021, or lacquered according to sample.
- Sides available in double glazing with black screen printing (30 mm thick); or in galvanized metal sheet painted in matt black RAL 7021 epoxy powder (40 mm thick); on request internal finish in mirrored stainless steel.
- 4000°K LED lighting placed under the top.
- Front glass panel H 125 mm.

REFRIGERATION

- Vertical display case with ventilated refrigeration.
- Incorporated condensing unit (UC) with R290 gas; remote condensing unit (NUC) with R452A gas.
- Ventilated defrost with compressor stop.
- Condensation evaporation tray with electric resistance for UC versions with R290 gas.
- Ground drain for versions with remote condensing unit (NUC).
- Low consumption fans for UC versions with R290 gas.
- Full touch control panel, dust-proof and water resistant.

OPTIONALS

- Front closure with manual night-time roller curtain.
- Seamless channelling of same services.
- Additional display shelf.
- 4000°K LED lighting on the shelves.
- Hook accessory for hanging cured meats in replacement of the upper shelf.
- Clear plastic price-holders and methacrylate product riser.
- Wheels, only in the UC version, with a height increase of 80 mm.

GOODY BISTROT is available in the following linear units, without sides:
L625, L937, L1250 and L1875 mm with a height of H2060 mm.

Side panels available in 2 versions:

- 1 glass side panel - 30 mm thick
- 1 solid side panel - 40 mm thick



MODULI DISPONIBILI | AVAILABLE UNITS

L 625

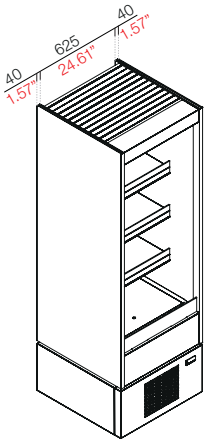

L 937

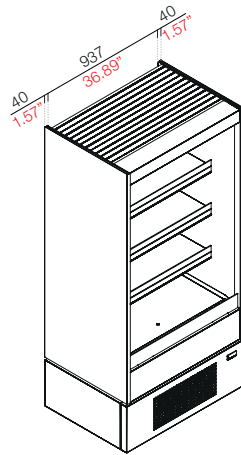

L 1250

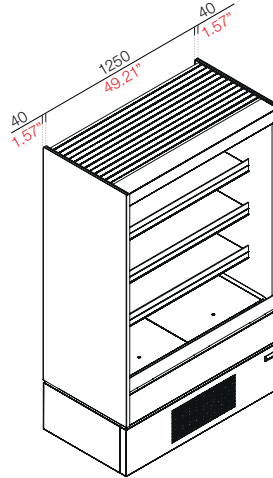

L 1875

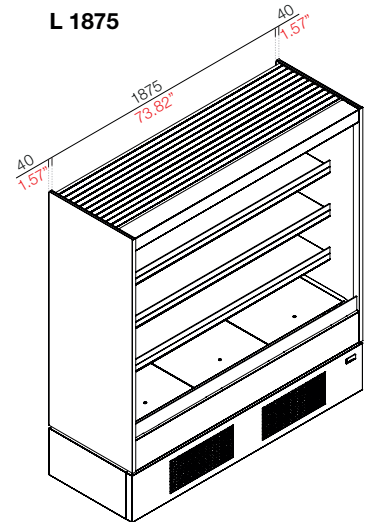

SCHEMA SCARICHI | DRAINAGES SYSTEM SCHEME

L 625 / L 937

LATO CLIENTE | CUSTOMER SIDE

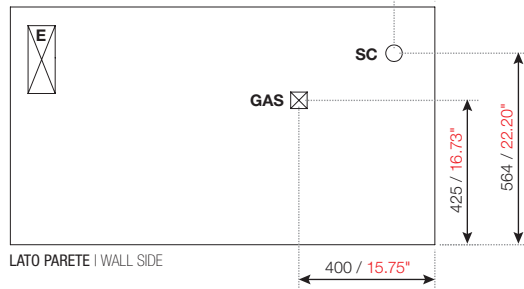

L 1250

LATO CLIENTE | CUSTOMER SIDE

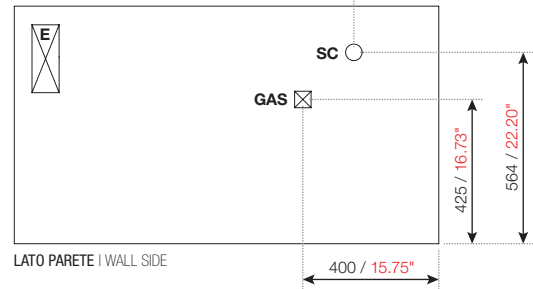

L 1875

LATO CLIENTE | CUSTOMER SIDE



E = alimentazione elettrica | electric power

GAS = uscita tubi gas | gas pipes outlet

L 625:

- mandata | delivery \varnothing 6 mm
- aspirazione | aspiration \varnothing 12 mm

L 937 - L 1250:

- mandata | delivery \varnothing 8 mm
- aspirazione | aspiration \varnothing 12 mm

L 1875 - L 2500:

- mandata | delivery \varnothing 8 mm
- aspirazione | aspiration \varnothing 14 mm

SC = scarico acqua | water drain
 \varnothing 40 mm

SEZIONE | SECTION VIEW

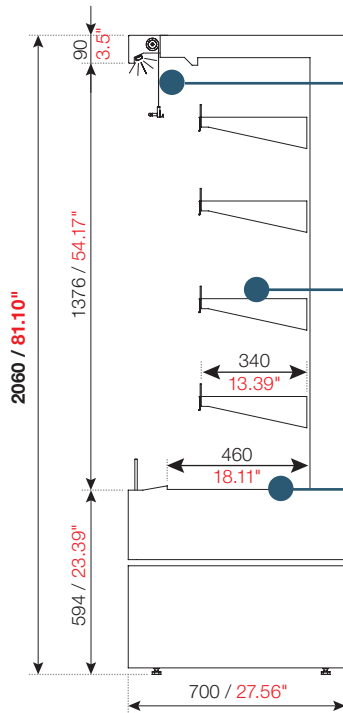

Tendina notturna optional (vedi optional)
Night-time roller curtain on request (see optionals)

Portata massima ripiani | Shelves maximum load
L 625 - 40 kg/m
L 937 - 45 kg/m
L 1250 - 55 kg/m
L 1875 - 70 kg/m

Portata massima piano espositivo | Display surface maximum load
95 kg/m - 105 kg/m² (carico uniformemente distribuito | Uniformly distributed load)

FINITURE INTERNE ED ESTERNE | INTERNAL AND EXTERNAL FINISHES



Pannello superiore nero RAL 7021

Upper front panel black RAL7021

Interno nero RAL 7021

Interior black RAL7021

Fianco in vetro camera spessore 30 mm

30mm-thick double glazed side panel

Disponibile anche fianco cieco verniciato nero RAL 7021, spessore 40 mm

Also available metal side panel painted black RAL 7021, 40mm-thick

Pannello inferiore nero RAL 7021

Lower front panel black RAL7021

INCLINAZIONE RIPIANI | SHELVES INCLINATION



Posizione orizzontale
Horizontal position



INCLINAZIONE 1
Inclination 1

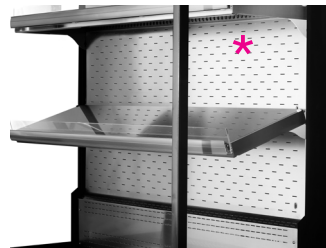

INCLINAZIONE 2
Inclination 2

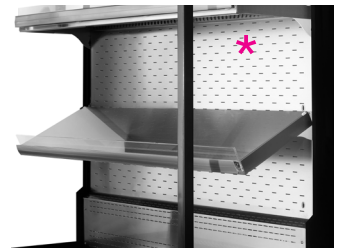

INCLINAZIONE 3
Inclination 3

* Finitura inox non disponibile sulla linea BISTROT
Stainless steel finish not available for BISTROT vertical display cases

**DIMENSIONI - PESO - IMBALLO | DIMENSIONS - WEIGHT - PACKAGING**

Modello Unit	Lunghezza * Length *		Profondità Depth		Altezza Height		Peso Weight		Dimensioni imballo LxPxA Packaging dimensions LxDxH		Peso prodotto con imballo Total weight with packaging	
	mm	in	mm	in	mm	in	kg	lb	mm	in	kg	lb
L 625	625*	36.89*	700	27.56	2060	81.1	140	309	1260x880xH2200	49.6"x34.65"x86.61"	180	397
L 937	937*	36.89*	700	27.56	2060	81.1	190	419	1260x880xH2200	49.6"x34.65"x86.61"	230	507
L 1250	1250*	49.21*	700	27.56	2060	81.1	213	470	1570x880xH2200	61.8"x34.65"x86.61"	263	580
L 1875	1875*	73.82*	700	27.56	2060	81.1	350	772	2200x880xH2200	86.6"x34.65"x86.61"	410	904

* Misure SENZA fianchi:

- 1 fianco in vetrocamera trasparente = 30 mm
- 1 fianco cieco = 40 mm

* Side panels NOT included:

- 1 double glazed side panel = 30 mm / 1.18"
- 1 solid side panel = 40 mm / 1.57"

DATI TECNICI | TECHNICAL DATA

CE		UC = con motore a bordo UC = with condensing unit on board								R290	230V/1/50Hz
Modello Unit	Potenza assorbita Current consumption		Resa Cooling capacity		Classe climatica Climate class			Consumo Kwh/annuo Kwh/year consumption	Classe di temperatura Temperature class	Classe energetica Energy label	
	W	A	W/h -10°C	BTU/h +14°F	°C	°F	H.R.				
L 625	616	3,7	643	2196	3	25°C	77°F	60%	6982	M2	
L 937	832	5,0	1064	3634	3	25°C	77°F	60%	8602	M2	
L 1250	1093	6,6	1203	4108	3	25°C	77°F	60%	10293	M2	
L 1875	1609	9,8	2269	7749	3	25°C	77°F	60%	13640	M2	

CE		UCR <20 m = motore remoto entro 20 metri UCR <20 m = with remote condensing unit within 20 meters							R452A	230V/1/50Hz	
Modello Unit	Potenza assorbita Current consumption		Resa Cooling capacity		Classe climatica Climate class			Consumo Kwh/annuo Kwh/year consumption	Classe di temperatura Temperature class	Classe energetica Energy label	
	W	A	W/h -10°C	BTU/h +14°F	°C	°F	H.R.				
L 625	615	3,84	748	2554	3	25°C	77°F	60%	5328	M2	
L 937	889	4,25	1215	4149	3	25°C	77°F	60%	6564	M2	
L 1250	1083	5,93	1513	5167	3	25°C	77°F	60%	7855	M2	
L 1875	1243	6,49	2360	8059	3	25°C	77°F	60%	10410	M2	

INDICAZIONI PER INSTALLAZIONE IN NICCHIA O A PARETE | INSTRUCTIONS FOR NICHE OR WALL INSTALLATION

VERSIONI UC = CON MOTORE A BORDO

1. installazione a parete
2. installazione in nicchia

UC VERSIONS = WITH CONDENSING UNIT ON BOARD

1. wall installation
2. niche installation

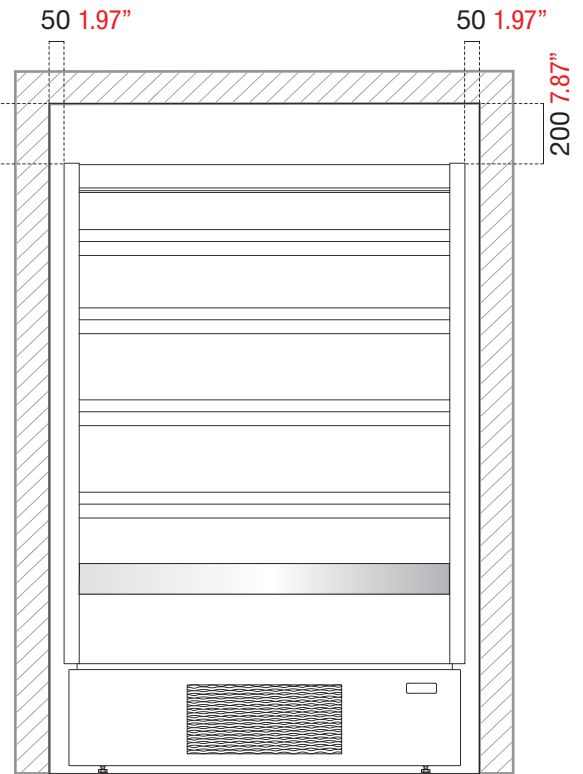
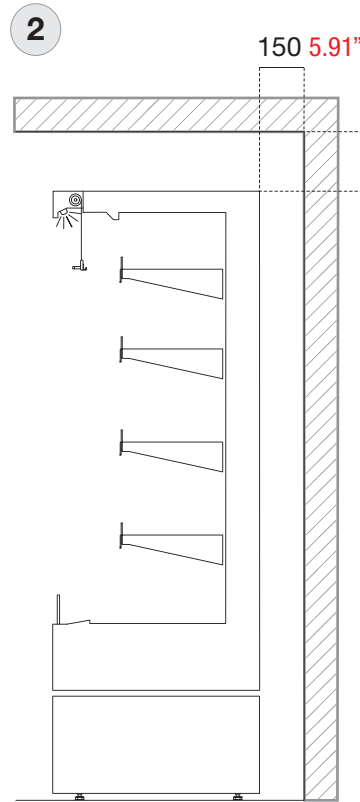
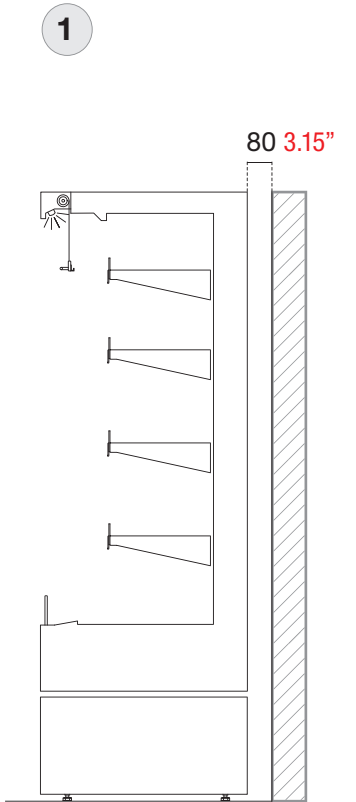

VERSIONI NUC = SENZA MOTORE A BORDO (con motore remoto)

1. installazione a parete
2. installazione in nicchia

NUC VERSIONS = WITHOUT CONDENSING UNIT (with remote condensing unit)

1. wall installation
2. niche installation

